

Code key

Metric

C	N	G	A	12	04	08	T	010	20	R	A	WG
1	2	3	4	5	6	7	8	9	10	11	12	13

Inch

C	N	G	A	4	3	2	T	03	20	R	A	WG
1	2	3	4	5	6	7	8	9	10	11	12	13

1 Insert shape

C	D
K	R
S	T
V	W

2 Insert clearance angle

B	C
E	N
P	O Specific description

4 Insert type

A	Q
G	R
M	T
N	W
P	X

3 Tolerances, metric

Class	S	IC / W1
G	±0.13	±0.025
M	±0.13	±0.05 - ±0.15 ¹⁾
U	±0.13	±0.08 - ±0.25 ¹⁾
E	±0.025	±0.025

¹⁾Varies depending on the size of IC. See below.

Inscribed circle IC mm	Tolerance class	
	M	U
3.97		
5.0		
5.56		
6.0	±0.05	±0.08
6.35		
8.0		
9.525		
10.0		
12.0	±0.08	±0.13
12.7		
15.875		
16.0	±0.10	±0.18
19.05		
20.0		
25.0	±0.13	±0.25
25.4		
31.75	±0.15	±0.25
32.0		

For positive inserts iC is valid for a sharp corner. See cutting edge condition F. (Picture 8).

3 Tolerances, inch

A: Theoretical diameter of the insert inscribed circle.
T: Thickness of the insert.
B: See figures.

Tolerances in inch

Class	B:	A:	T:
A	±.0002	±.001	±.001
B	.0002	.001	.005
C	.0005	.001	.001
D	.0005	.001	.005
E	.001	.001	.001
F	.0002	.0005	.001
G	.001	.001	.005
H	.0005	.0005	.001
J	.0002	.002-.005	.001
K	.0005	.002-.005	.001
L	.001	.002-.005	.001
M	.002-.005	.002-.005	.005
U	.005-.012	.005-.010	.005
N	.002-.010	.002-.004	.001

5 Insert size

Inscribed circle, inch	Cutting edge length, metric	Cutting edge length, inch							
		C	D	R	S	T	V	W	K
	IC mm								
	IC inch								
	3.18					05			
	3.97					06			
	5.0			05					
	6.0		06						
	6.35		07			11	11		
	8.0			08					
	9.525		09	09	09	16	16	06	16 ¹⁾
	10.0			10					
	12.0			12					
	12.7		15			22	22	08	
	15.875			15		27			
	16.0			16					
	19.0		19		19	33			
	20.0								
	25.0					25 ¹⁾			
	25.4		25		25				
	31.75					31			
	32					32			

For rectangular and rhombic inserts cutting edge length is indicated in mm.

¹⁾ For insert shape K (KNMX, KNUX) only the theoretical cutting edge length is indicated.
²⁾ Inch base design

6 Insert thickness, S mm, inch

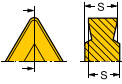

Metric		Inch	
01	S = 1.59	1.	S = .0625
T1	S = 1.98	(1.2)	S = .075
02	S = 2.38	(1.5)	S = 3/32
03	S = 3.18	2	S = 1/8
T3	S = 3.97	(2.5)	S = 5/32
04	S = 4.76	3	S = 3/16
05	S = 5.56	4	S = 1/4
06	S = 6.35	5	S = 5/16
07	S = 7.94	6	S = 3/8
09	S = 9.52	6.3	S = .394
10	S = 10.00	7.6	S = .475
12	S = 12.00		





7 Nose radius, RE mm, inch



Metric:	Inch:	Actual dimension:
00 = 0	00	Round
01 = 0.1	03	.004
02 = 0.2	0	.008
04 = 0.4	1 = 1/64	.0156
05 = 0.5		
08 = 0.8	2 = 1/32	.0312
10 = 1.0		
12 = 1.2	3 = 3/64	.047
15 = 1.5		
16 = 1.6	4 = 1/16	.0625
24 = 2.4	6 = 3/32	.094
32 = 3.2	8 = 1/8	.125

Note: See example for approximation of metric nose radius.
16=1.6mm=.063=.0625 inch

8 Cutting edge condition

F		Sharp cutting edge
E (A)		ER treated cutting edge A (inch) E (metric)
T		Negative land
K		Double negative lands
S		Negative land and ER treated cutting edge

12 Insert Type (CBN)

To allow a variety of machining demands to be met, several types of inserts comprising CBN and PCD is manufactured. To easy identify the different types Sandvik Coromant uses a letter to denote the variants.

- A CBN, Multi Corner Inserts
 - Fully indexable
 - CBN top to bottom of the carbide carrier corners
- B CBN, Multi Corner Inserts
 - Fully indexable
 - CBN brazed to the top and bottom of the carbide carrier corners.
- E CBN, Single tip inserts
 - Non-indexable
 - CBN brazed to the top of one of the carbide carrier corners
- F CBN, Multi tip inserts
 - Indexable
 - CBN brazed to each corner of the carbide carrier
- D CBN, Full top inserts
 - Indexable
 - CBN sintered to the complete top surface of the carbide carrier
- M CBN, Solid inserts
 - Fully indexable
 - Complete insert mode from CBN

9 Chamfer width

ISO mm	ANSI inch
010 BN = 0.10	03 BN = (.003)
015 BN = 0.15	06 BN = (.006)
020 BN = 0.20	08 BN = (.0078)
025 BN = 0.25	08 BN = (.0098)
070 BN = 0.70	30 BN = (.030)
150 BN = 1.50	60 BN = (.060)
200 BN = 2.00	80 BN = (.080)

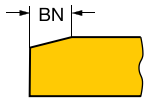

10 Chamfer angle, degrees

15 GB = 15°	30 GB = 30°
20 GB = 20°	35 GB = 35°
25 GB = 25°	

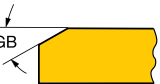

11 Hand of insert

Inserts designed solely for machining in left or right direction are indicated as below.

R	Right hand design
L	Left hand design

13 Wiper Geometry

Our unique Wiper and Xcel technologies can be used to boost productivity and generate superior surface finish.





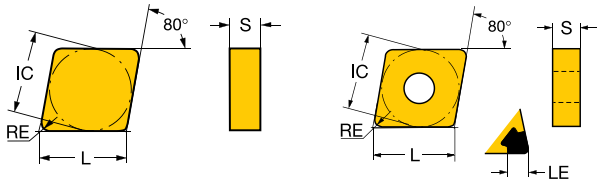

- WG Wiper geometry for general purpose machining
 - Allows high feed rates in HPT
 - Suitable for finish machining of GCI
- WH Wiper geometry optimized for HPT
 - Low cutting forces for superior surface finish
 - Designed for peak performance at HPT finishing feed rates
- Xcel Allows the use of higher feed rates than other wiper geometries
- XA Maintains surface finish

Negative basic-shape inserts

T-Max® P

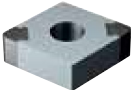
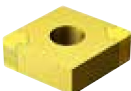
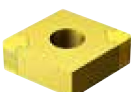
Rhombic 80°

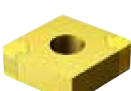

			LE	LE"	ISO CODE	K		H			ANSI CODE
						7525	7925	7015	7025	7525	
	12	1/2	2.6	.102	CNGX1204L025-18AXA			☆	☆		CNGX1204L025-18AXA
	09	3/8	2.3	.091	CNGA090304S01030AWH				☆		CNGA321S0330AWH
			2.2	.087	CNGA090308S01030AWH				☆		CNGA322S0330AWH
	12	1/2	2.8	.110	CNGA120404S01030AWH				☆		CNGA431S0330AWH
			2.7	.106	CNGA120408S01030AWH				☆	☆	CNGA432S0330AWH
			2.0	.079	CNGA120408S02035AWH				☆	☆	CNGA432S0835AWH
			2.7	.106	CNGA120412S01030AWH				☆		CNGA433S0330AWH
	09	3/8	2.3	.091	CNGA090304T01030AWH				☆		CNGA321T0330AWH
			2.2	.087	CNGA090308T01030AWH				☆		CNGA322T0330AWH
	12	1/2	2.8	.110	CNGA120404T01030AWH				☆		CNGA431T0330AWH
			2.7	.106	CNGA120408T01030AWH				☆		CNGA432T0330AWH
		2.7	.106	CNGA120412T01030AWH				☆		CNGA433T0330AWH	
	12	1/2	2.7	.106	CNGA120408S01030AWG				☆	☆	CNGA432S0330AWG
			2.7	.106	CNGA120412S01030AWG				☆	☆	CNGA433S0330AWG
	12	1/2	2.8	.110	CNGA120404T01020BWG			☆		☆	CNGA431T0320BWG
			2.7	.106	CNGA120408T01020BWG			☆		☆	CNGA432T0320BWG
	09	3/8	2.3	.091	CNGA090304S01030A				☆	☆	CNGA321S0330A
			2.2	.087	CNGA090308S01030A				☆	☆	CNGA322S0330A
			2.0	.079	CNGA090308S02035A				☆		CNGA322S0835A
	12	1/2	1.8	.071	CNGA120404S01020A				☆	☆	CNGA431S0320A
			2.8	.110	CNGA120404S01030A				☆	☆	CNGA431S0330A
			1.8	.071	CNGA120404S02035A				☆		CNGA431S0835A
			2.8	.110	CNGA120404S02035B				☆		CNGA431S0835B
			2.0	.079	CNGA120408S01018A				☆	☆	CNGA432S0318A
			2.7	.106	CNGA120408S01030A				☆	☆	CNGA432S0330A
			2.0	.079	CNGA120408S01530B				☆	☆	CNGA432S0630B
			2.0	.079	CNGA120408S02035A				☆	☆	CNGA432S0835A
			2.8	.110	CNGA120408S02035B				☆	☆	CNGA432S0835B
			2.3	.091	CNGA120412S01018A				☆	☆	CNGA433S0318A
			2.7	.106	CNGA120412S01030A				☆	☆	CNGA433S0330A
			2.3	.091	CNGA120412S01530B				☆	☆	CNGA433S0630B
			2.3	.091	CNGA120412S02035A				☆	☆	CNGA433S0835A
			2.8	.110	CNGA120412S02035B				☆	☆	CNGA433S0835B
		2.6	.102	CNGA120416S01030A				☆	☆	CNGA434S0330A	
		2.7	.106	CNGA120416S02035A				☆	☆	CNGA434S0835A	



Note: Grade 7025 is uncoated.

Negative basic-shape inserts

T-Max® P

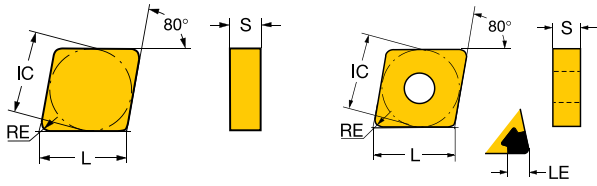
Rhombic 80°

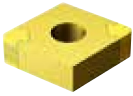

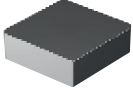
		LE	LE"	ISO CODE	K		H			ANSI CODE	
					7925	7015	7025	7525	CB20		
Finishing		12	1/2	2.8	.110	CNGA120404T01020B	☆			☆	CNGA431T0320B
				2.7	.106	CNGA120408T01020B	☆			☆	CNGA432T0320B
				2.0	.079	CNGA120408T01030A		☆			CNGA432T0330A
				2.7	.106	CNGA120412T01020B	☆			☆	CNGA433T0320B
				2.3	.091	CNGA120412T01030A		☆			CNGA433T0330A
		12	1/2	2.0	.079	CNGA120408EA			☆		CNGA432AA
				2.3	.091	CNGA120412EA			☆		CNGA433AA
		12	1/2	2.8	.110	CNMA120404S01020E				☆	CNMA431S0320E
				2.8	.110	CNMA120408S01020E				☆	CNMA432S0320E
				2.7	.106	CNMA120412S01020E				☆	CNMA433S0320E
		12	1/2			CNGN120412S02520M		☆			CNG433S0820M
						CNGN120416S02520M		☆			CNG434S0820M

Note: Grade 7025 is uncoated.

Negative basic-shape inserts

T-Max® P

Rhombic 55°

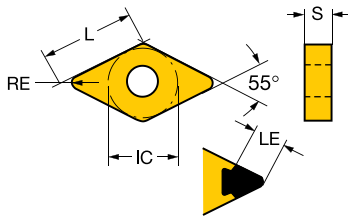

		LE	LE"	ISO CODE	K				H				ANSI CODE
					7525	7015	7025	7525	7525	CB20	7525	7015	
	15	1/2	3.4	.134	DNGA150408S01030AWH		☆	☆					DNGA432S0330AWH
			2.1	.083	DNGA150408S02035AWH				☆	☆			DNGA432S0835AWH
			3.0	.118	DNGA150412S01030AWH				☆	☆			DNGA433S0330AWH
			2.4	.094	DNGA150412S02035AWH				☆				DNGA433S0835AWH
	11	3/8	1.8	.071	DNGA110404S01020A				☆				DNGA331S0320A
			3.0	.118	DNGA110404S01030A				☆	☆			DNGA331S0330A
			2.1	.083	DNGA110408S01020A				☆	☆			DNGA332S0320A
			2.6	.102	DNGA110408S01030A				☆	☆			DNGA332S0330A
			2.1	.083	DNGA110408S02035A					☆			DNGA332S0835A
			2.2	.087	DNGA110412S01030A				☆				DNGA333S0330A
	15	1/2	1.8	.071	DNGA150404S01020A				☆				DNGA431S0320A
			3.8	.150	DNGA150404S01030A				☆	☆			DNGA431S0330A
			1.8	.071	DNGA150404S02035A					☆			DNGA431S0835A
			2.1	.083	DNGA150408S01020A					☆			DNGA432S0320A
			3.4	.134	DNGA150408S01030A					☆	☆		DNGA432S0330A
			2.1	.083	DNGA150408S01530B						☆		DNGA432S0630B
			2.1	.083	DNGA150408S02035A				☆	☆			DNGA432S0835A
			3.0	.118	DNGA150412S01030A				☆	☆			DNGA433S0330A
		2.4	.094	DNGA150412S01530B						☆		DNGA433S0630B	
		2.4	.094	DNGA150412S02035A				☆	☆			DNGA433S0835A	
		2.9	.114	DNGA150416S01030A				☆	☆			DNGA434S0330A	
	11	3/8	3.4	.134	DNGA110404T01020B		☆			☆			DNGA331T0320B
			3.0	.118	DNGA110408T01020B		☆				☆		DNGA332T0320B
	15	1/2	2.1	.083	DNGA150408EA				☆				DNGA432AA
			2.4	.094	DNGA150412EA					☆			DNGA433AA
			2.9	.114	DNGA150416EA					☆			DNGA434AA
	15	1/2	3.3	.130	DNMA150404S01020E						☆		DNMA431S0320E
			2.9	.114	DNMA150408S01020E						☆		DNMA432S0320E
			2.6	.102	DNMA150412S01020E						☆		DNMA433S0320E





Note: Grade 7025 is uncoated.

Negative basic-shape inserts

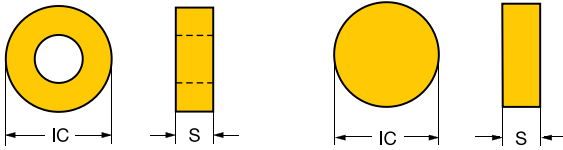
T-Max®

Round











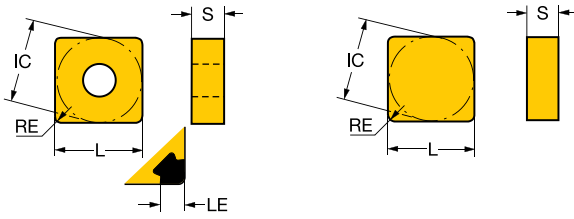



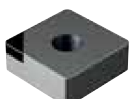

					K	H	
				ISO CODE	7925	CB20	ANSI CODE
					CB50		
Finishing		06	1/4	RNGN060300S02520M	☆		RNG22S1020M
				RNGN060400S02520M	☆		RNG23S1020M
		09	3/8	RNGN090300S02520M	☆		RNG32S1020M
		12	1/2	RNGN120300S02520M	☆		RNG42S1020M
				RNGN120400S02520M	☆		RNG43S1020M
		15	5/8	RNGN150400S02520M	☆		RNG53S1020M
		25	1	RNGN250400S02520M	☆		RNG83S1020M
Medium		12	1/2	RNGN120400FD		☆	RNG43FD
Medium		09	3/8	RNGA090300S01020D		☆	RNGA32S0320D

Negative basic-shape inserts

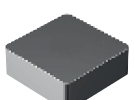
T-Max® P

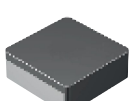
Square

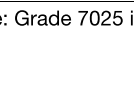

			LE	LE"	ISO CODE	K			H			ANSI CODE					
						7525	7925	CB50	7015	7025	7925		CB20	CB50			
Finishing			09	3/8	2.1	.083	SNGA090308S01030A				☆	☆		SNGA322S0330A			
					1.4	.055	SNGA090308S02035B								SNGA322S0835B		
					2.1	.083	SNGA090312S02035B						☆		SNGA323S0835B		
			12	1/2	2.7	.106	SNGA120408S01030A				☆	☆		SNGA432S0330A			
					2.7	.106	SNGA120412S01030A				☆	☆			SNGA433S0330A		
					2.7	.106	SNGA120412S02035A						☆			SNGA433S0835A	
					2.8	.110	SNGA120412S02035B							☆		SNGA433S0835B	
															☆		SNGA433S0835B
			09	3/8	2.1	.083	SNGA090308T01020B					☆		SNGA322T0320B			
							2.1	.083	SNGA090312T01020B					☆		SNGA323T0320B	
					12	1/2	2.7	.106	SNGA120408T01020B	☆					☆		SNGA432T0320B
							2.7	.106	SNGA120412T01020B	☆						☆	
			12	1/2	3.4	.134	SNMA120404S01020E						☆	SNMA431S0320E			
							3.4	.134	SNMA120408S01020E						☆	SNMA432S0320E	
							3.4	.134	SNMA120412S01020E						☆		SNMA433S0320E
			09	3/8			SNGN090312S02520M		☆					SNG323S1020M			
					12	1/2			SNGN120412S02520M		☆					SNG433S1020M	
											SNGN120416S02520M		☆				
			12	1/2			SNGN120408FD			☆			☆	SNG432FD			
									SNGN120412FD			☆			☆	SNG433FD	
									SNGN120416FD			☆			☆		SNG434FD



Note: Grade 7025 is uncoated.

Negative basic-shape inserts

T-Max® P

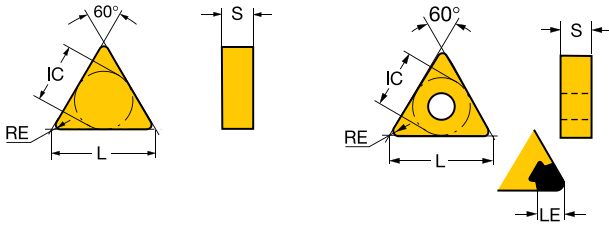
Triangular

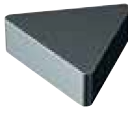
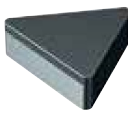

			LE	LE"	ISO CODE	K		H				ANSI CODE		
						7925	CB50	7015	7025	7525	CB20		CB50	
Finishing			11	1/4	1.6	.063	TNGA110304S01030A			☆	☆			TNGA221S0330A
					1.3	.051	TNGA110308S01030A			☆	☆			TNGA222S0330A
			16	3/8	2.9	.114	TNGA160404S01030A			☆	☆			TNGA331S0330A
					2.6	.102	TNGA160408S01030A			☆	☆			TNGA332S0330A
					2.0	.079	TNGA160408S01530B					☆		TNGA332S0630B
					2.0	.079	TNGA160408S02035A					☆		TNGA332S0835A
					2.8	.110	TNGA160408S02035B					☆		TNGA332S0835B
					2.3	.091	TNGA160412S01030A			☆	☆			TNGA333S0330A
					2.3	.091	TNGA160412S02035A					☆		TNGA333S0835A
					16	3/8	3.6	.142	TNMA160404S01020E					☆
			3.3	.130	TNMA160408S01020E						☆	TNMA332S0320E		
			3.0	.118	TNMA160412S01020E						☆	TNMA333S0320E		
		22	1/2	3.2	.126	TNMA220408S01020E					☆	TNMA432S0320E		
			2.9	.114	TNMA220412S01020E						☆	TNMA433S0320E		
				16	3/8		TNGN160408S02520M	☆						TNG332S1020M
							TNGN160412S02520M	☆						TNG333S1020M
			22	1/2		TNGN220412FD		☆				☆	TNG433FD	

Note: Grade 7025 is uncoated.

Negative basic-shape inserts

T-Max® P

Trigon 80°

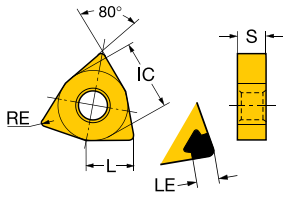

				ISO CODE		ANSI CODE				
		LE	LE''			7525	7015	7025	7525	
Finishing		06 3/8 2.3 .091	.091	WNGA060404S01030AWH				☆	WNGA331S0330AWH	
		2.2 .087	.087	WNGA060408S01030AWH				☆	WNGA332S0330AWH	
		08 1/2 2.8 .110	.110	WNGA080404S01030AWH				☆	WNGA431S0330AWH	
		2.7 .106	.106	WNGA080408S01030AWH				☆	WNGA432S0330AWH	
		2.7 .106	.106	WNGA080412S01030AWH				☆	WNGA433S0330AWH	
		06 3/8 2.3 .091	.091	WNGA060404T01030AWH				☆	WNGA331T0330AWH	
		2.2 .087	.087	WNGA060408T01030AWH				☆	WNGA332T0330AWH	
		08 1/2 2.8 .110	.110	WNGA080404T01030AWH				☆	WNGA431T0330AWH	
		2.7 .106	.106	WNGA080408T01030AWH				☆	WNGA432T0330AWH	
		2.7 .106	.106	WNGA080412T01030AWH				☆	WNGA433T0330AWH	
		06 3/8 2.3 .091	.091	WNGA060404T01020BWG				☆	WNGA331T0320BWG	
		2.2 .087	.087	WNGA060408T01020BWG				☆	WNGA332T0320BWG	
		08 1/2 2.8 .110	.110	WNGA080404T01020BWG				☆	WNGA431T0320BWG	
		2.7 .106	.106	WNGA080408T01020BWG				☆	WNGA432T0320BWG	
		06 3/8 2.3 .091	.091	WNGA060404S01030A				☆	☆	WNGA331S0330A
		2.2 .087	.087	WNGA060408S01030A				☆	☆	WNGA332S0330A
		08 1/2 2.8 .110	.110	WNGA080404S01030A				☆	☆	WNGA431S0330A
		2.7 .106	.106	WNGA080408S01030A				☆	☆	WNGA432S0330A
		2.0 .079	.079	WNGA080408S02035A				☆	☆	WNGA432S0835A
	2.7 .106	.106	WNGA080412S01030A				☆	☆	WNGA433S0330A	
	06 3/8 2.3 .091	.091	WNGA060404T01020B				☆		WNGA331T0320B	
	2.2 .087	.087	WNGA060408T01020B				☆		WNGA332T0320B	
	08 1/2 2.8 .110	.110	WNGA080404T01020B				☆		WNGA431T0320B	
	2.7 .106	.106	WNGA080408T01020B				☆		WNGA432T0320B	
	2.7 .106	.106	WNGA080412T01020B				☆		WNGA433T0320B	



Note: Grade 7025 is uncoated.

Negative basic-shape inserts

T-Max® P

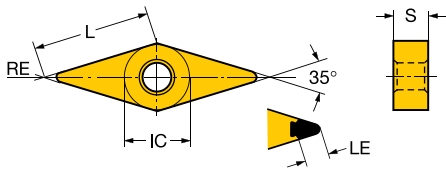
Rhombic 35°



						H			
				LE	LE"	ISO CODE	7015	7025	ANSI CODE
Finishing		16	3/8	2.1	.083	VNGA160404S01020A	☆	☆	VNGA331S0320A
				4.2	.165	VNGA160404S01030A	☆	☆	VNGA331S0330A
				2.4	.094	VNGA160408S01020A	☆	☆	VNGA332S0320A
				3.3	.130	VNGA160408S01030A	☆	☆	VNGA332S0330A
				2.4	.094	VNGA160408S02035A	☆	☆	VNGA332S0835A

Note: Grade 7025 is uncoated.

Positive basic-shape inserts

CoroTurn® 107

Rhombic 80°

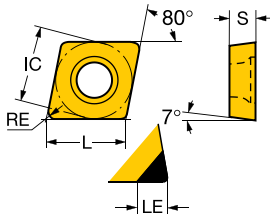

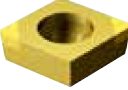
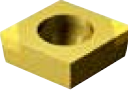
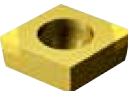
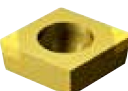
		LE	LE"	ISO CODE	K			H			ANSI CODE	
					7525	7015	7025	7025	7925			
	09	3/8	2.6	.102	CCGW09T304S01020FWH				☆		CCGW3(2.5)1S0320FWH	
			1.8	.071	CCGW09T304S01530FWH				☆		CCGW3(2.5)1S0630FWH	
			2.6	.102	CCGW09T308S01020FWH				☆		CCGW3(2.5)2S0320FWH	
			2.6	.102	CCGW09T312S01020FWH				☆		CCGW3(2.5)3S0320FWH	
		06	1/4	1.8	.071	CCGW060204T01030FWH			☆	☆		CCGW2(1.5)1T0330FWH
				2.0	.079	CCGW060208T01030FWH			☆	☆		CCGW2(1.5)2T0330FWH
		09	3/8	2.6	.102	CCGW09T304T01020FWH			☆	☆		CCGW3(2.5)1T0320FWH
				2.5	.098	CCGW09T308T01020FWH			☆	☆		CCGW3(2.5)2T0320FWH
		06	1/4	1.8	.071	CCGW060204S01020F			☆	☆		CCGW2(1.5)1S0320F
				1.8	.071	CCGW060204S01030F			☆	☆	☆	CCGW2(1.5)1S0330F
				2.0	.079	CCGW060208S01030F			☆	☆	☆	CCGW2(1.5)2S0330F
		09	3/8	2.6	.102	CCGW09T304S01020F			☆	☆	☆	CCGW3(2.5)1S0320F
			1.8	.071	CCGW09T304S01530F			☆	☆	☆	CCGW3(2.5)1S0630F	
			2.5	.098	CCGW09T308S01020F			☆	☆	☆	CCGW3(2.5)2S0320F	
			2.0	.079	CCGW09T308S01530F			☆	☆	☆	CCGW3(2.5)2S0630F	
			2.6	.102	CCGW09T312S01020F			☆	☆		CCGW3(2.5)3S0320F	
			2.3	.091	CCGW09T312S01530F			☆	☆		CCGW3(2.5)3S0630F	
		06	1/4	1.5	.059	CCGW060202T01030F			☆	☆		CCGW2(1.5)0T0330F
			2.6	.102	CCGW060204T01020F			☆	☆		CCGW2(1.5)1T0320F	
			1.8	.071	CCGW060204T01030F			☆	☆		CCGW2(1.5)1T0330F	
			2.0	.079	CCGW060208T01030F			☆	☆		CCGW2(1.5)2T0330F	
	09	3/8	2.6	.102	CCGW09T304T01020F			☆	☆		CCGW3(2.5)1T0320F	
			2.5	.098	CCGW09T308T01020F			☆	☆		CCGW3(2.5)2T0320F	



Note: Grade 7025 is uncoated.

Positive basic-shape inserts

CoroTurn® 107

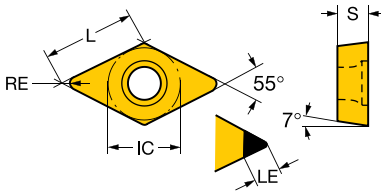
Rhombic 55°

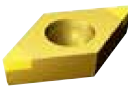
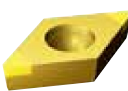

	LE	LE"	ISO CODE	K				H				ANSI CODE
				7525	7015	7025	7525	CB20	7525	7015	7025	
	11	3/8	2.1	.083	DCGW11T308S01020FWH				DCGW3(2.5)2S0320FWH			
	07	1/4	1.8	.071	DCGW070204S01020F				DCGW2(1.5)1S0320F			
			1.8	.071	DCGW070204S01030F				DCGW2(1.5)1S0330F			
			2.0	.079	DCGW070208S01030F				DCGW2(1.5)2S0330F			
	11	3/8	1.8	.071	DCGW11T304S01020F				DCGW3(2.5)1S0320F			
			1.8	.071	DCGW11T304S01530F				DCGW3(2.5)1S0630F			
			2.8	.110	DCGW11T308S01020F				DCGW3(2.5)2S0320F			
			2.1	.083	DCGW11T308S01530F				DCGW3(2.5)2S0630F			
			2.4	.094	DCGW11T312S01020F				DCGW3(2.5)3S0320F			
			2.4	.094	DCGW11T312S01530F				DCGW3(2.5)3S0630F			
	07	1/4	1.5	.059	DCGW070202T01030F				DCGW2(1.5)0T0330F			
			3.2	.126	DCGW070204T01020F				DCGW2(1.5)1T0320F			
	11	3/8	3.4	.134	DCGW11T302T01020F				DCGW3(2.5)0T0320F			
			3.2	.126	DCGW11T304T01020F				DCGW3(2.5)1T0320F			
			2.1	.083	DCGW11T308T01020F				DCGW3(2.5)2T0320F			
	11	3/8	3.6	.144	DCMW11T304S01020E				DCMW3(2.5)1S0320E			
			3.4	.132	DCMW11T308S01020E				DCMW3(2.5)2S0320E			

Note: Grade 7025 is uncoated.

Positive basic-shape inserts

CoroTurn® 107

Rhombic 35°

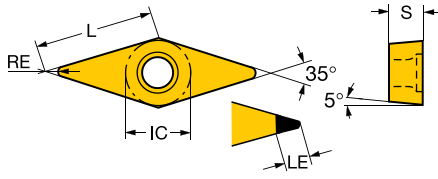

						K			H						
						7525	7015	7025	7525						
				LE	LE"	ISO CODE						ANSI CODE			
Finishing		16	3/8	4.2	.165	VBGW160404S01020F		☆	☆			VBGW331S0320F			
				3.0	.118	VBGW160404S01030F				☆		VBGW331S0330F			
				3.1	.122	VBGW160404S01530F				☆		VBGW331S0630F			
				3.3	.130	VBGW160408S01020F				☆	☆	VBGW332S0320F			
				3.1	.122	VBGW160408S01530F				☆	☆	VBGW332S0630F			
			16	3/8	4.2	.165	VBGW160404T01020F	☆					VBGW331T0320F		
				3.3	.130	VBGW160408T01020F	☆						VBGW332T0320F		

Note: Grade 7025 is uncoated.

Positive basic-shape inserts

CoroTurn® 107

Triangular

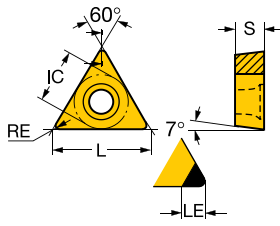

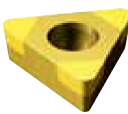
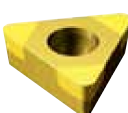
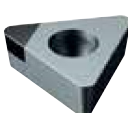
		LE	LE"	ISO CODE	K				H				ANSI CODE	
					7525	7015	7025	7525	CB20	7525	7015	7025		7525
Finishing		09	7/32	3.2	.126	TCGW090202S01020F	☆	☆	☆	☆	☆	☆	TCGW1.8(1.5)0S0320F	
				3.0	.118	TCGW090204S01020F	☆	☆	☆	☆	☆	☆	TCGW1.8(1.5)1S0320F	
				1.8	.071	TCGW090204S01030F	☆	☆	☆	☆	☆	☆	TCGW1.8(1.5)1S0330F	
				1.8	.071	TCGW090204S01530F	☆	☆	☆	☆	☆	☆	TCGW1.8(1.5)1S0630F	
				1.8	.071	TCGW110204S01020F	☆	☆	☆	☆	☆	☆	TCGW2(1.5)1S0320F	
			11	1/4	3.0	.118	TCGW110204S01020F	☆	☆	☆	☆	☆	TCGW2(1.5)1S0630F	
				1.8	.071	TCGW110208S01020F	☆	☆	☆	☆	☆	☆	TCGW2(1.5)2S0320F	
				2.7	.106	TCGW110208S01530F	☆	☆	☆	☆	☆	☆	TCGW2(1.5)2S0630F	
				3.0	.118	TCGW110304S01020F	☆	☆	☆	☆	☆	☆	TCGW221S0320F	
				1.8	.071	TCGW110304S01530F	☆	☆	☆	☆	☆	☆	TCGW221S0530F	
			09	7/32	3.0	.118	TCMW090204S01020E					☆	TCMW1.8(1.5)1S0320E	
				11	1/4	3.0	.118	TCMW110304S01020E					☆	TCMW221S0320E
						3.0	.118	TCMW110308S01020E					☆	TCMW222S0320E
						3.0	.118	TCMW110204S01020E					☆	TCMW2(1.5)1S0320E
						3.0	.118	TCMW110208S01020E					☆	TCMW2(1.5)2S0320E

CoroTurn® 111

Triangular

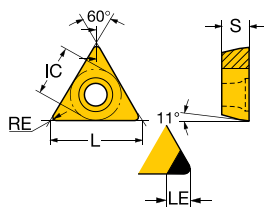

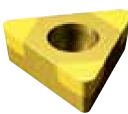
		LE	LE"	ISO CODE	K				H				ANSI CODE
					7525	7015	7025	7525	CB20	7525	7015	7025	
Finishing		11	1/4	3.0	.118	TPGW110304S01020F	☆	☆	☆	☆	☆	☆	TPGW221S0320F
				2.7	.106	TPGW110308S01020F	☆	☆	☆	☆	☆	☆	TPGW222S0320F



Note: Grade 7025 is uncoated.

Positive basic-shape inserts

T-Max®

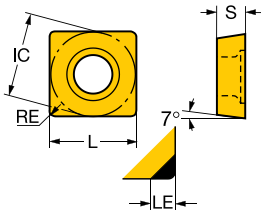
Square

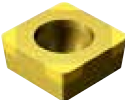
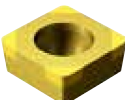

				H				
					7015	7025	7525	
		LE	LE"	ISO CODE	☆	☆	☆	ANSI CODE
Finishing		09 3/8 1.8 .071		SCGW09T304S01030F	☆	☆		SCGW3(2.5)1S0330F
				SCGW09T308S01030F	☆	☆		SCGW3(2.5)2S0330F
				SCGW09T308S01530F			☆	SCGW3(2.5)2S0630F
		09 3/8 2.8 .110		SCGW09T304T01020F			☆	SCGW3(2.5)1T0320F
				SCGW09T308T01020F			☆	SCGW3(2.5)2T0320F
				SCGW09T308T01530F			☆	SCGW3(2.5)2T0530F

Note: Grade 7025 is uncoated.

CoroTurn® TR

Rhombic 55°

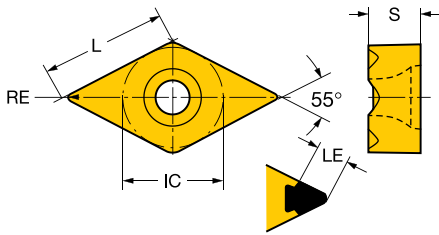

						H		
				ISO CODE		7015	7025	
Finishing		13	13	3.0	.118	TR-DC1304S01020F	☆ ☆	TR-DC1304S01020F
				3.0	.118	TR-DC1308S01020F	☆ ☆	TR-DC1308S01020F

Rhombic 35°

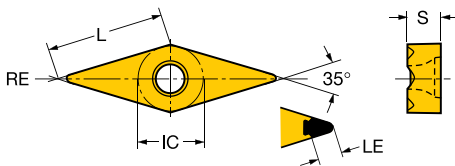

						H		
				ISO CODE		7015	7025	
Finishing		13	13	3.0	.118	TR-VB1304S01020F	☆ ☆	TR-VB1304S01020F
				3.0	.118	TR-VB1308S01020F	☆ ☆	TR-VB1308S01020F

Note: Grade 7025 is uncoated.

For code key, see Turning tools catalogue 2011.

CoroTurn® XS inserts

Turning

KAPR 98°

PSIR -8°

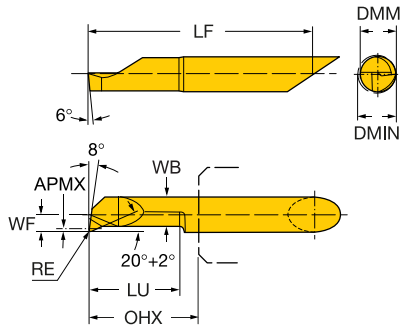

CZC MS	APMX	DMIN	DMM	LU	Ordering code	H 7015	Dimensions, mm, inch				
							RE	WB	WF	LF	OHX
04	0.20	1.7	4	6.0	CXS-04T098-10-1706R	☆	0.1	1.05	0.70	27.2	9
	.008	.067	.157	.236			.004	.041	.028	1.073	.354
	0.20	2.2	4	9.0	CXS-04T098-10-2209R	☆	0.1	1.55	0.95	27.2	12
	.008	.087	.157	.354			.004	.061	.037	1.073	.472
	0.20	2.7	4	10.0	CXS-04T098-15-2710R	☆	0.2	2.05	1.20	27.3	13
	.008	.106	.157	.394			.006	.081	.047	1.073	.512
	0.20	3.2	4	15.0	CXS-04T098-15-3215R	☆	0.2	2.55	1.45	32.3	18
	.008	.126	.157	.591			.006	.100	.057	1.270	.709
	0.20	3.7	4	15.0	CXS-04T098-15-3715R	☆	0.2	3.05	1.70	32.2	18
	.008	.146	.157	.591			.006	.120	.067	1.270	.709
	0.30	4.2	4	10.0	CXS-04T098-15-4210R	☆	0.2	3.45	1.95	27.3	13
	.012	.165	.157	.394			.006	.136	.077	1.073	.512
	0.30	4.2	4	15.0	CXS-04T098-15-4215R	☆	0.2	3.45	1.95	32.3	18
	.012	.165	.157	.591			.006	.136	.077	1.270	.709
	0.30	4.2	4	20.0	CXS-04T098-15-4220R	☆	0.2	3.45	1.95	37.3	23
	.012	.165	.157	.787			.006	.136	.077	1.467	.906
0.30	4.2	4	25.0	CXS-04T098-15-4225R	☆	0.2	3.45	1.95	43.3	28	
.012	.165	.157	.984			.006	.136	.077	1.703	1.102	
05	0.50	5.2	5	10.0	CXS-05T098-20-5210R	☆	0.2	4.25	2.4	32.2	13
	.020	.205	.197	.394			.008	.167	.096	1.270	.512
	0.50	5.2	5	20.0	CXS-05T098-20-5220R	☆	0.2	4.25	2.45	42.2	23
	.020	.205	.197	.787			.008	.167	.096	1.663	.906
	0.50	5.2	5	25.0	CXS-05T098-20-5225R	☆	0.2	4.25	2.45	47.2	28
	.020	.205	.197	.984			.008	.167	.096	1.860	1.102
06	0.50	5.2	5	30.0	CXS-05T098-20-5230R	☆	0.2	4.25	2.45	57.2	33
	.020	.205	.197	1.181			.008	.167	.096	2.254	1.299
	0.50	6.2	6	15.0	CXS-06T098-20-6215R	☆	0.2	5.25	2.95	37.2	18
	.020	.244	.236	.591			.008	.207	.116	1.467	.709
	0.50	6.2	6	20.0	CXS-06T098-20-6220R	☆	0.2	5.25	2.95	42.2	23
	.020	.244	.236	.787			.008	.207	.116	1.663	.906
07	0.50	6.2	6	25.0	CXS-06T098-20-6225R	☆	0.2	5.25	2.95	47.2	28
	.020	.244	.236	.984			.008	.207	.116	1.860	1.102
	0.50	6.2	6	30.0	CXS-06T098-20-6230R	☆	0.2	5.25	2.95	52.2	33
	.020	.244	.236	1.181			.008	.207	.116	2.057	1.299
	0.50	6.2	6	40.0	CXS-06T098-20-6240R	☆	0.2	5.25	2.95	62.2	43
	.020	.244	.236	1.575			.008	.207	.116	2.451	1.693
07	0.50	7.2	7	25.0	CXS-07T098-20-7225R	☆	0.2	6.25	3.45	47.2	28
	.020	.283	.276	.984			.008	.246	.136	1.860	1.102
	0.50	7.2	7	30.0	CXS-07T098-20-7230R	☆	0.2	6.25	3.45	52.2	33
	.020	.283	.276	1.181			.008	.246	.136	2.057	1.299
	0.50	7.2	7	40.0	CXS-07T098-20-7240R	☆	0.2	6.25	3.45	62.2	43
	.020	.283	.276	1.575			.008	.246	.136	2.451	1.693
07	0.50	7.2	7	50.0	CXS-07T098-20-7250R	☆	0.2	6.25	3.45	72.2	53
	.020	.283	.276	1.968			.008	.246	.136	2.844	2.087

For code key, see Turning tools catalogue 2011

R = Right hand

TSYC	Tolerances, mm				Tolerances, inch			
	RETOLL	RETOLU	LLTOLL	LLTOLU	RETOLL"	RETOLU"	LLTOLL"	LLTOLU"
CXS-xxT098..R/L	-0.02	0.02	-0.02	0.02	-.0008	.0008	-.0008	.0008

LLTOLL, LLTOLU Tolerances LF

CoroTurn® XS inserts

Grooving

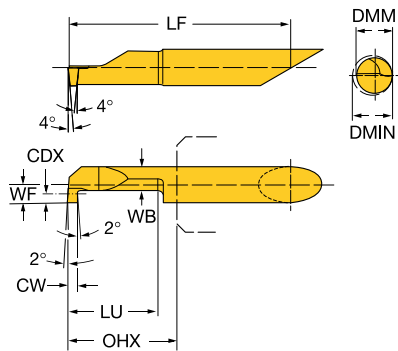

CZC MS	CDX	DMIN	DMM	LU	Ordering code	H Dimensions, mm, inch					
						7015	WB	WF	LF	OHX	CW
06	1.8	6.2	6.0	15.0	CXS-06G100-6215R	☆	3.95	2.95	37.3	18	1.0
	.071	.244	.236	.591			.156	.116	1.469	.709	.039
	1.8	6.2	6.0	15.0	CXS-06G150-6215R	☆	3.95	2.95	37.3	18	1.5
	.071	.244	.236	.591			.156	.116	1.469	.709	.059

R = Right hand

Threading

V-profile 60°

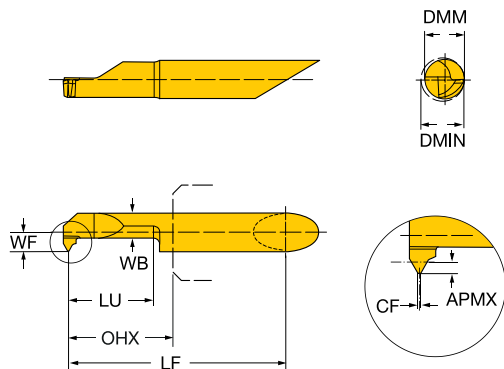

CZC MS	APMX	DMIN	DMM	LU	Ordering code	H Dimensions, mm, inch					
						7015	WB	WF	LF	OHX	CF
06	0.55	6.2	6.0	15.0	CXS-06TH100VM-6215R	☆	3.55	2.95	37.3	18	0.12
	.022	.244	.236	.591			.140	.116	1.469	.709	.005
	0.81	6.2	6.0	15.0	CXS-06TH150VM-6215R	☆	3.55	2.95	37.3	18	0.18
	.032	.244	.236	.591			.140	.116	1.469	.709	.007

For code key, see Turning tools catalogue 2011

R = Right hand

TSYC	Tolerances, mm				Tolerances, inch			
	CWTOLL	CWTOLU	LLTOLL	LLTOLU	CWTOLL"	CWTOLU"	LLTOLL"	LLTOLU"
CXS-xxT098..R/L	-0	0.05	-0.02	0.02	-0	.002	-.0008	.0008

LLTOLL, LLTOLU Tolerances LF

CoroCut® 1- and 2-edge

Grooving

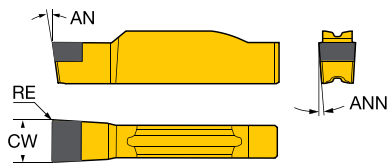
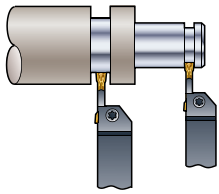

Tailor Made

		Dimensions, mm, inch						Ordering code	H		
		SSC	CW	CW"	ANN	AN	RE		RE"	7015	CB20
Low feed		G	3.00	.118	7°	7°	0.20	.008	N123G1-0300-0002-GE	☆	
			3.18	.125	7°	7°	0.20	.008	N123G1-0318-0002-GE	☆	
		H	4.00	.157	7°	7°	0.20	.008	N123H1-0400-0002-GE	☆	
			4.70	.185	7°	7°	0.20	.008	N123H1-0470-0002-GE	☆	
			5.00	.197	7°	7°	0.20	.008	N123H1-0500-0002-GE	☆	
		J	6.00	.236	7°	7°	0.20	.008	N123J1-0600-0002-GE	☆	
		K	6.35	.250	7°	7°	0.20	.008	N123K1-0635-0002-GE	☆	
		L	8.00	.315	7°	7°	0.20	.008	N123L1-0800-0002-GE	☆	
		G	3.00	.118	7°	7°	0.40	.016	N123G1-030004S01025	☆	
		H	4.00	.157	7°	7°	0.40	.016	N123H1-040004S01025	☆	
			5.00	.197	7°	7°	0.40	.016	N123H1-050004S01025	☆	
		J	6.00	.236	7°	7°	0.40	.016	N123J1-060004S01025	☆	
		L	8.00	.315	7°	7°	0.80	.031	N123L1-080008S01025	☆	

N = Neutral

For code key, see Turning tools catalogue 2011

TSYC	Tolerances, mm				Tolerances, inch			
	CWTOLL	CWTOLU	RETOLL	RETOLU	CWTOLL"	CWTOLU"	RETOLL"	RETOLU"
N123x1..S	-0.02	0.02	-0.05	0.05	-.0008	.0008	-.002	.002

CoroCut® 1- and 2-edge

Profiling

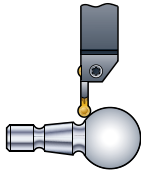

TSYC N123x1..S

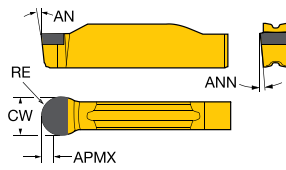

N/R/L123x1-RE

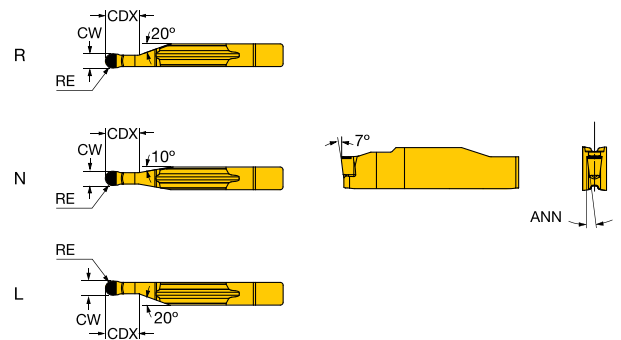

		Dimensions, mm, inch												H
		SSC	CW	CW"	ANN	AN	RE	RE"	APMX	APMX"	Ordering code		7015	
Low feed		F	3.00	.118	7°	7°	1.50	.059	1.30	.051	N123F1-0300S01025	☆	☆	
		H	4.00	.157	7°	7°	2.00	.079	1.80	.071	N123H1-0400S01025	☆	☆	
			5.00	.197	7°	7°	2.50	.098	2.30	.091	N123H1-0500S01025	☆	☆	
		J	6.00	.236	7°	7°	3.00	.118	2.80	.110	N123J1-0600S01025	☆	☆	

		Dimensions, mm, inch												H
		SSC	CW	CW"	ANN	RE	RE"	CDX	CDX"	APMX	APMX"	Ordering code	7015	CB20
Low feed		H	2.00	.079	7°	1.00	.039	5.0	.197	0.80	.031	R/L123H1-0200-RE	☆	☆
			2.00	.079	7°	1.00	.039	5.0	.197	0.80	.031	N123H1-0200-RE	☆	☆
		F	3.00	.118	7°	1.50	.059			1.30	.051	N123F1-0300-RE	☆	☆
			3.18	.125	7°	1.59	.063			1.40	.055	N123F1-0318-RE	☆	☆
		H	4.00	.157	7°	2.00	.079			1.80	.071	N123H1-0400-RE	☆	☆
			5.00	.197	7°	2.50	.098			2.30	.091	N123H1-0500-RE	☆	☆
		J	6.00	.236	7°	3.00	.118			2.80	.110	N123J1-0600-RE	☆	☆
			6.35	.250	7°	3.18	.125			3.00	.118	N123J1-0635-RE	☆	☆
		L	8.00	.315	7°	4.00	.157			3.80	.150	N123L1-0800-RE	☆	☆

For code key, see Turning tools catalogue 2011

N = Neutral, R = Right hand, L = Left hand

TSYC	Tolerances, mm				Tolerances, inch			
	CWTOLL	CWTOLU	RETOLL	RETOLU	CWTOLL"	CWTOLU"	RETOLL"	RETOLU"
N123x1..S	-0.02	0.02	-0.01	0.01	-0.0008	.0008	-0.0004	.0004
N123x1-RE	-0.02	0.02	-0.01	0.01	-0.0008	.0008	-0.0004	.0004
R/L123x1-RE	-0.02	0.02	-0.01	0.01	-0.0008	.0008	-0.0004	.0004

CoroCut® MB inserts

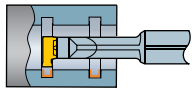

TSYC MB..G

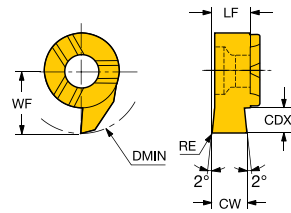

MB..T093

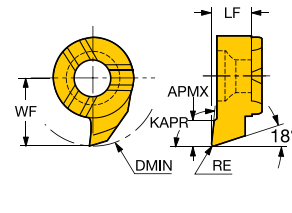

MB-xxTH..MM..R/L

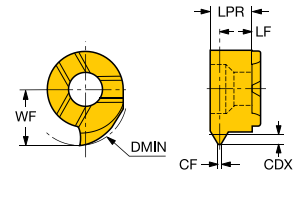

Grooving

		H										Dimensions, mm, inch				
		SSC	RE	RE"	CDX	CDX"	Ordering code	7015	DMIN	DMIN"	WF	WF"	LF	LF"	CW	CW"
	07	0	0	2.8	.110	MB-07G100-00-11R	☆	11.00	.433	6.8	.268	3.9	.154	1.0	.039	
		0	0	2.8	.110	MB-07G150-00-11R	☆	11.00	.433	6.8	.268	3.9	.154	1.5	.059	

R = Right hand

Turning

		H										Dimensions, mm, inch			
		SSC	RE	RE"	APMX	APMX"	KAPR	Ordering code	7015	DMIN	DMIN"	WF	WF"	LF	LF"
	07	0.20	.008	1.80	.071	93°	MB-07T093-02-10R	☆	10.00	.394	5.6	.220	3.9	.154	

R = Right hand

Threading

Metric 60°

		H										Dimensions, mm, inch					
		SSC	CDX	CDX"	CF	CF"	TP	Ordering code	7015	DMIN	DMIN"	WF	WF"	LF	LF"	LPR	LPR"
	07	0.5	.021	0.12	.005	1.0	MB-07TH100MM-10R	☆	10.00	.394	5.8	.228	3.2	.126	3.8	.150	
		0.8	.032	0.18	.007	1.5	MB-07TH150MM-10R	☆	10.00	.394	5.8	.228	3.0	.118	3.8	.150	

For code key, see Turning tools catalogue 2011

R = Right hand

	Tolerances, mm						Tolerances, inch					
	CWTOLL	CWTOLU	RETOLL	RETOLU	LLTOLL	LLTOLU	CWTOLL"	CWTOLU"	RETOLL"	RETOLU"	LLTOLL"	LLTOLU"
TSYC												
MB..G	-0	0.05			-0.02	0.02	-0	.002			-.0008	.0008
MB..T093			-0.02	0.02	-0.02	0.02			-.0008	.0008	-.0008	.0008
MB-xxTH..MM..R/L					-0.02	0.02					-.0008	.0008

LLTOLL, LLTOLU Tolerances LF

CoroThread® 266

V-profile 60° Non-topping

Threading

TSYC 266R/LG..VM..A

266R/LL..VM..A

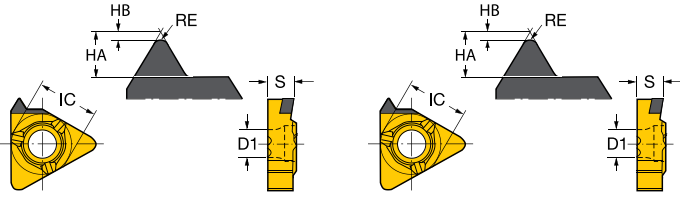

External

							H	Dimensions, mm, inch						
							7015							
			TPN	TPX	TPIN	TPIX	Ordering code	HA	HB	RE	IC	D1	S	
	16	3/8	1.0	2.0	12	24	266RG-16VM01A001EE	☆	1.68	0.14	0.13	9.53	4.4	3.97
									.066	.006	.005	.375	.173	.156
	16	3/8	1.5	3.0	8	16	266RG-16VM01A002EE	☆	2.64	0.20	0.20	9.53	4.4	3.97
									.104	.008	.008	.375	.173	.156

Internal

							H	Dimensions, mm, inch						
							7015							
			TPN	TPX	TPIN	TPIX	Ordering code	HA	HB	RE	IC	D1	S	
	16	3/8	1.5	3.0	8	16	266RL-16VM01A002EE	☆	2.54	0.09	0.09	9.52	4.4	3.97
									.100	.004	.004	.375	.173	.156

For code key, see Turning tools catalogue 2011

266R = Right hand